

# SEMITÜRK®



MODEL:  
STCL30A212

MODEL:  
STCH30A212

CHEST TYPE DUMPER SEMI-TRAILER



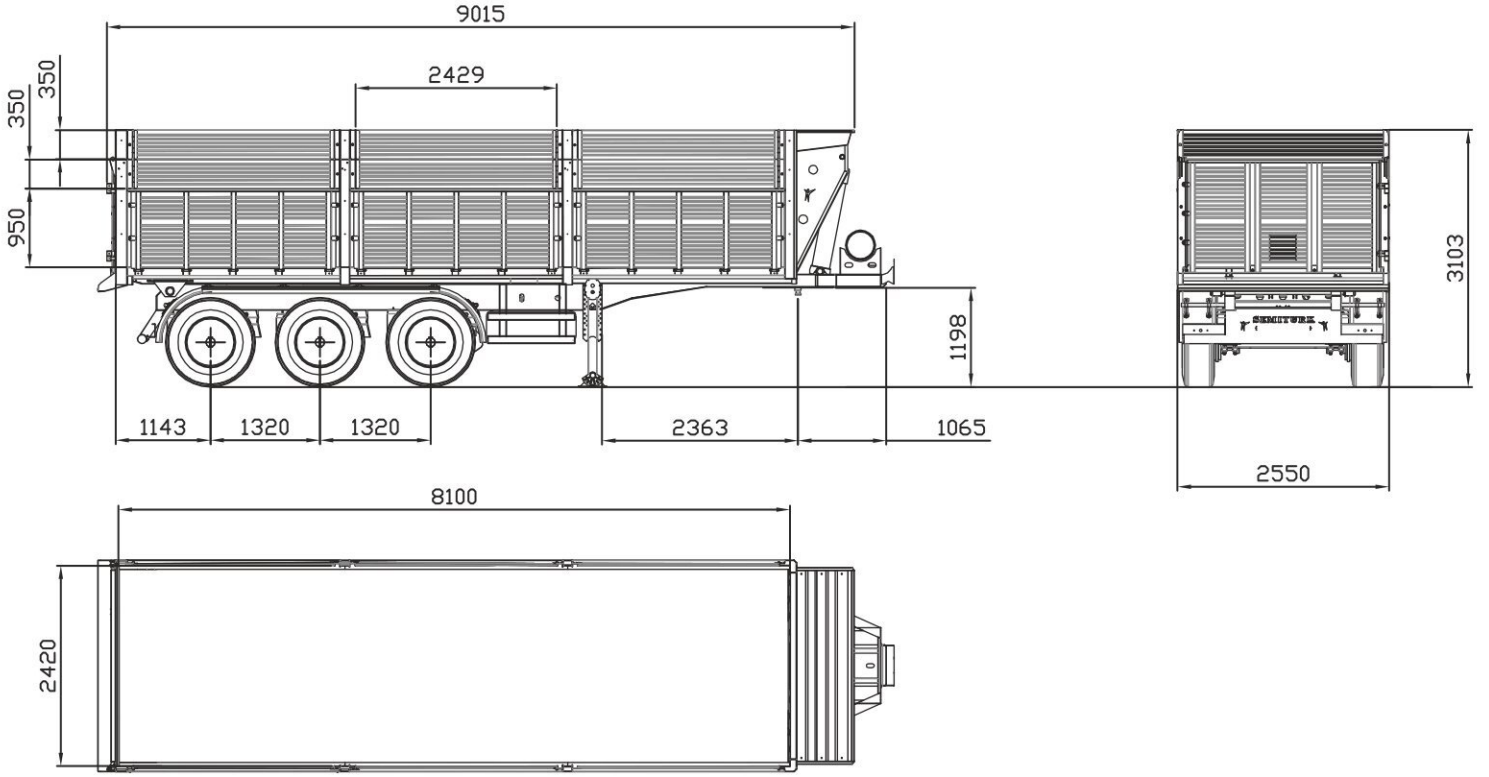

# SEMITÜRK

SEMI-TRAILER		STCL30A212	STCH30A212
Weight and Dimensions	Length of Dumper	8.100 mm	8.100 mm
	Total Width	2.550 mm	2.550 mm
	Gates	950 mm	950 mm
	Accessional Gates	350 + 350 mm	350 + 350 mm
	Dead Weight	6.200 kg	7.200 kg
Main Structure and Chassis		Main structure, chassis and others are made of 'Domex 700'. Gates and accessional gates are made of 'Domex Docol'	Main structure, chassis and others are made of 'Domex 700'. Gates and accessional gates are made of 'Domex Docol'
Tires		385 / 65 R 22.5" size 6 + 1 units tubeless tires	
Brake System		Dual circuit brake hardware, EBS, 2S/2M & 4S/2M	
King Pin		2", bolt - connected in DIN standards	
Landing Gears		Telescopic landing gears with two mechanical speeds; Dynamic: 25.000 kg, Static : 50.000 kg	
Axles		3 axles BPW compatible, 12 ton capacity, square section	
Suspension System		Air - suspension "5813", 100 mm Z-type springs, suspension valves and shock absorbers	
Electricity Hardware 'E certified'		24 V Lighting system, 7 pole distribution cable and required hardware for traffic regulation	
Standard Accessories		1 x spare tire holder, 1 x tool box, 1 x water tank, wheel chock and holder, FRP mudguard, ladder	